

POLOLU QTRX-HD-07RC REFLECTANCE SENSOR

ARRAY

USER'S GUIDE

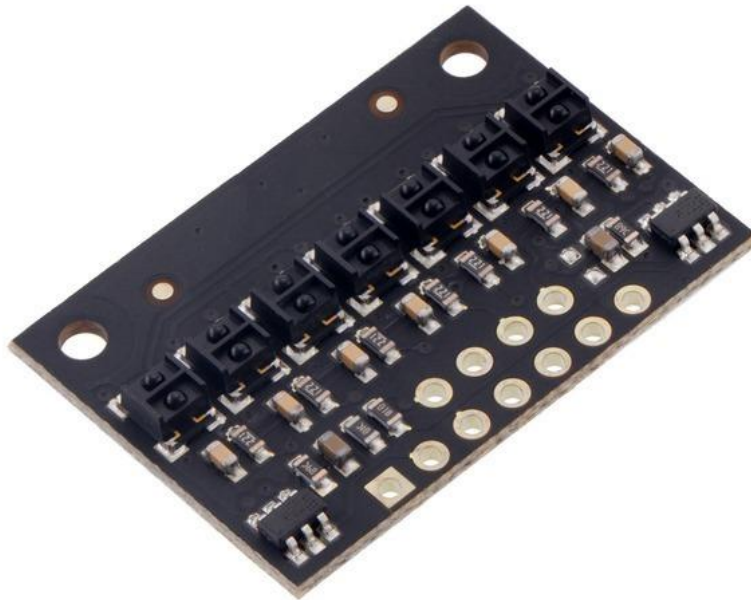

OVERVIEW

These QTR reflectance sensor arrays feature seven IR emitter/phototransistor pair modules in a high-density (4 mm pitch) arrangement, which makes them well suited for applications that require precise detection of changes in contrast,

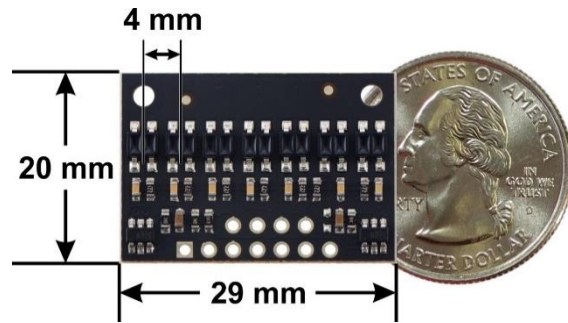

such as line sensing. Unlike our original QTR sensor modules, these units have integrated LED drivers that provide brightness control independent of the supply voltage, which can be anywhere from 2.9 V to 5.5 V, while enabling optional dimming to any of 32 possible brightness settings. There are separate controls for the odd-numbered and even-numbered LEDs, which gives you extra options for detecting light reflected at various angles. See the “Emitter control” section below for more information on using this feature.

Two different sensor options are available, denoted by “QTR” or “QTRX” in the product name. The “QTR” versions feature lower-cost sensor modules without lenses while the “QTRX” versions feature higher-performance sensor modules with lenses, which allow similar performance at a much lower IR LED current.

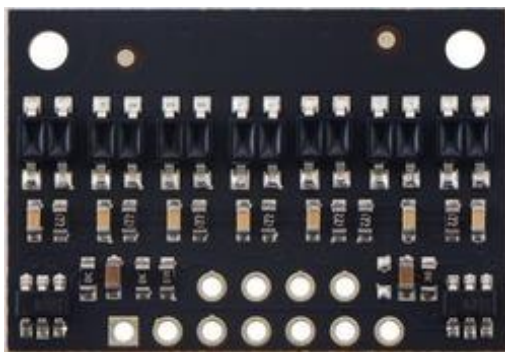

QTR-HD-07RC Reflectance Sensor Array

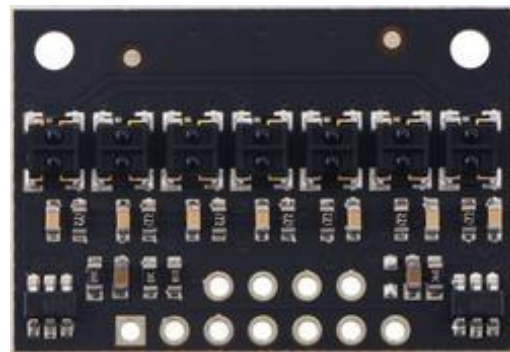

QTRX-HD-07RC Reflectance Sensor Array

Each sensor option is available in two output types: “A” versions with analog voltage outputs between 0 V and VCC, and “RC” versions with outputs that can be read with a digital I/O line on a microcontroller by first setting the line high and then releasing it and timing how long it takes to read as low (typically anywhere from a few microseconds to a few milliseconds). The lower the output voltage or shorter the voltage decay time, the higher the reflectance. The following simplified schematic diagrams show the circuits for the individual channels:

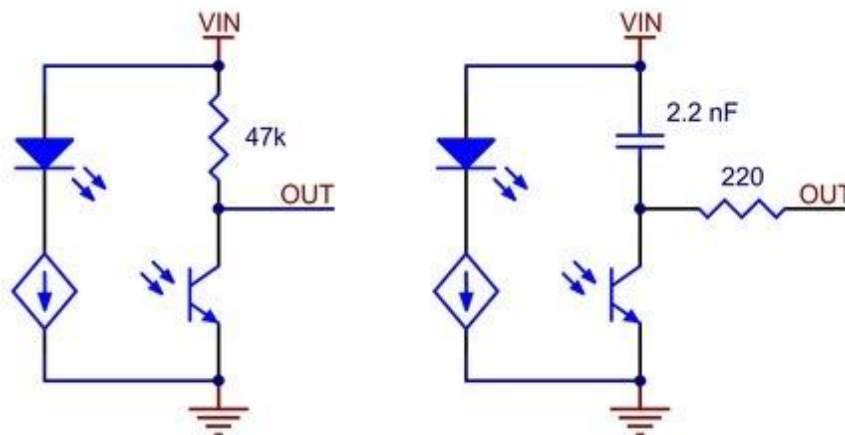

Schematic diagrams of individual QTR HD sensor channels for A version (left) and RC version (right).

INTERFACING WITH THE OUTPUTS OF THE QTRX-HD-07RC

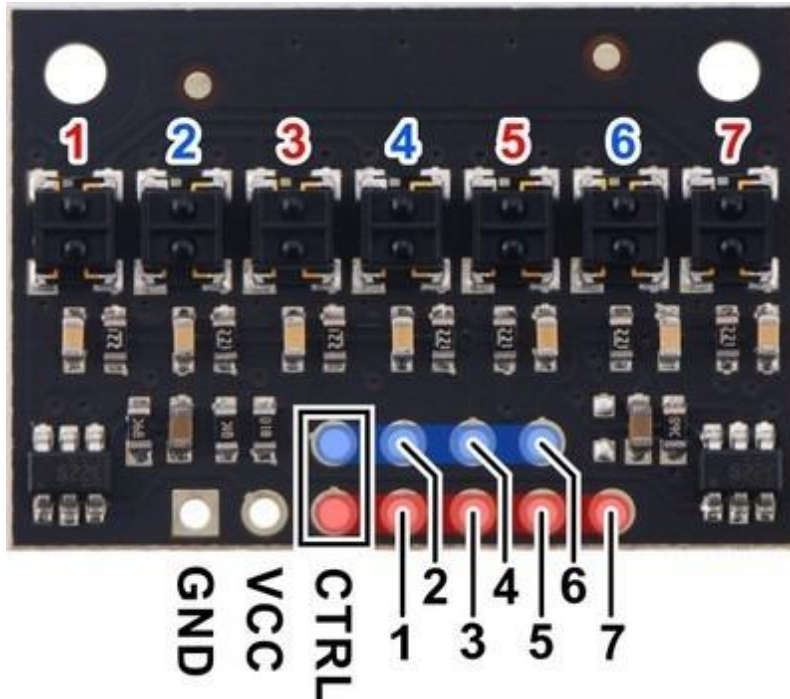

The QTRX-HD-07RC module has seven identical sensor outputs that require a digital I/O line capable of driving the output line high and then measuring the time for the output voltage to decay. The typical sequence for reading a sensor is:

1. Turn on IR LEDs (optional).
2. Set the I/O line to an output and drive it high.
3. Allow at least 10 μs for the sensor output to rise.
4. Make the I/O line an input (high impedance).
5. Measure the time for the voltage to decay by waiting for the I/O line to go low.
6. Turn off IR LEDs (optional).

These steps can typically be executed in parallel on multiple I/O lines.

With a strong reflectance, the decay time can be as low as a few microseconds; with no reflectance, the decay time can be up to a few milliseconds. The exact time of the decay depends on your microcontroller's I/O line

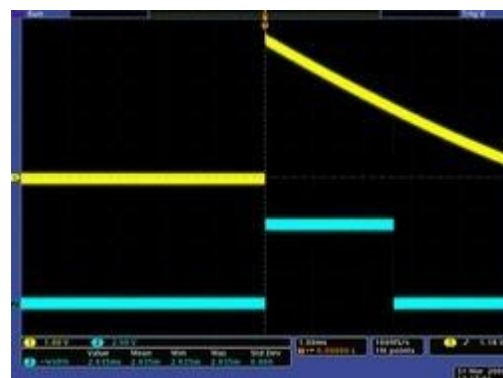

QTR-1RC output (yellow) when 1/8" above a black line and microcontroller timing of that output (blue).

characteristics. Meaningful results can be available within 1 ms in typical cases (i.e. when not trying to measure subtle differences in low-reflectance scenarios), allowing up to 1 kHz sampling of all 7 sensors. If lower-frequency sampling is sufficient, you can achieve substantial power savings by turning off the LEDs. For example, if a 100 Hz sampling rate is acceptable, the LEDs can be off 90% of the time, lowering average current consumption from 15 mA to less than 2 mA.

Our [Arduino library](#) makes it easy to use these sensors with an Arduino or compatible controller by providing functions for reading the individual sensor values and, for line-following applications, converting those sensor readings into a line position.

EMITTER CONTROL

This reflectance sensor array maintains a constant current through its IR emitters, keeping the emitters' brightness constant, independent of the supply voltage (2.9 V to 5.5 V). The emitters can be controlled with the board's CTRL pins. By default, these are connected together with a 1 kΩ resistor and pulled up, turning on all the emitters by default and allowing them to be controlled with a signal on either pin, but the CTRL ODD and CTRL EVEN pins can be driven differently for separate control of the odd-numbered and even-numbered emitters.

Driving a CTRL pin low for at least 1 ms turns off the associated emitter LEDs, while driving it high (or allowing the board to pull it high) turns on the emitters with the board's default (full) current of **3.5 mA**. For more advanced use, the CTRL pin can be pulsed low to cycle the associated emitters through 32 dimming levels.

To send a pulse, you should drive the CTRL pin low for at least 0.5 μs (but no more than 300 μs), then high for at least 0.5 μs; (it should remain high after the last pulse). Each pulse causes the driver to advance to the next dimming level, wrapping around to 100% after the lowest-current level. Each dimming level corresponds to a 3.33% (0.12 mA)

reduction in current, except for the last three levels, which represent a 1.67% (0.06 mA) reduction, as shown in the table below. Note that turning the LEDs off with a >1 ms pulse and then back on resets them to full current.

Dimming level (pulses)	Emitter current (%)	Emitter current (mA)	Dimming level (pulses)	Emitter current (%)	Emitter current (mA)
0	100.00%	3.5	16	46.67%	1.63
1	96.67%	3.38	17	43.33%	1.52
2	93.33%	3.27	18	40.00%	1.4
3	90.00%	3.15	19	36.67%	1.28
4	86.67%	3.03	20	33.33%	1.17
5	83.33%	2.92	21	30.00%	1.05
6	80.00%	2.8	22	26.67%	0.93
7	76.67%	2.68	23	23.33%	0.82
8	73.33%	2.57	24	20.00%	0.7
9	70.00%	2.45	25	16.67%	0.58
10	66.67%	2.33	26	13.33%	0.47
11	63.33%	2.22	27	10.00%	0.35
12	60.00%	2.1	28	6.67%	0.23
13	56.67%	1.98	29	5.00%	0.18
14	53.33%	1.87	30	3.33%	0.12
15	50.00%	1.75	31	1.67%	0.06

For example, to reduce the emitter current to 50% (15 mA), you would apply 15 low pulses to the CTRL pin and then keep it high after the last pulse.

SCHEMATIC

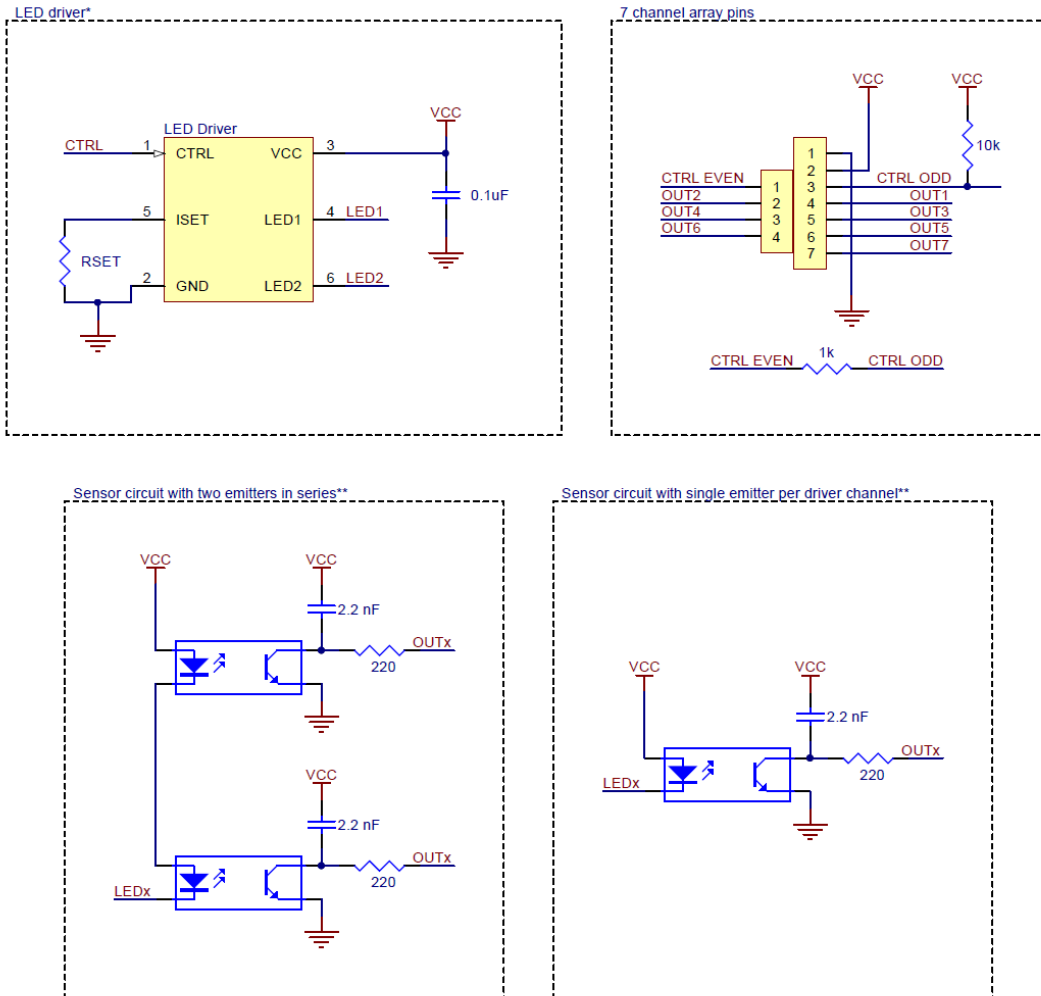

*Number of LED drivers on each array depends on the number of sensors populated
**Module constructed from combination of single and dual sensor circuits

Schematic diagram of the QTR-HD-07RC and QTRX-HD-07RC Reflectance Sensor Arrays.