

Ultrasonic Flow Sensor with Plastic Pipe Specification

■ **Model: HS0014-000//RC15/HS-US0004-040-01**

■ Introduction

As the signal generating unit of the ultrasonic cold water meter, the Ultrasonic Cold Water Meter Body is used for supplying accurate, stable and continuous ultrasonic signals to the meter circuit.

The Ultrasonic Cold Water Meter Body is designed for residential use and conforms to the Urban Construction Industry Standard CJT434-2013 of The PRC, taking into account the water metering needs of different regions. The built-in transducers feature high sensitivity, stable performance, high reliability and low power consumption.

■ Structure and Principle

1. Mechanical construction:

Constructed by a pair of ultrasonic flow sensors and a set of pipe components.

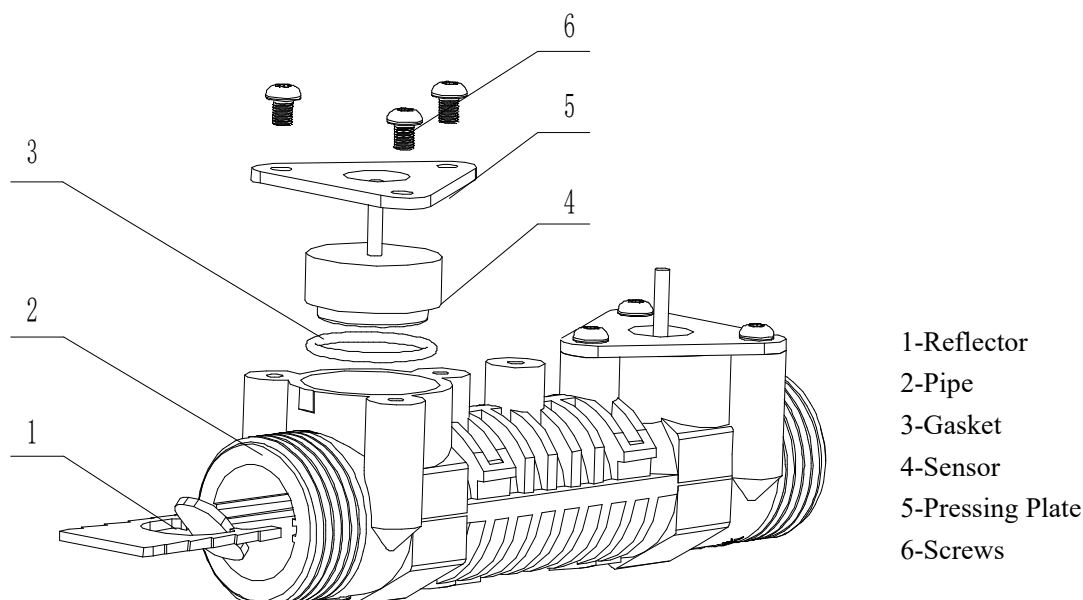

2. Measuring principle:

Measurement may be performed based on the transit time method. By measuring the difference in the downstream and upstream propagation time of ultrasonic pulses, the flow

rate of the water in the pipe can be calculated.

■ Technical Data

1. Electrical characteristics of the built-in sensors:

No.	Items	Specification	Note
1	Resonant Frequency	975±30 kHz	By impedance analyzer 4294A
2	Resonant impedance	≤110 Ω	By impedance analyzer 4294A
3	Static capacitance	1150±20% pF	By digital electric bridge at 1000Hz/1V

T=25±3°C, H=45~75%R.H

2. Meter body parameters:

No.	Items	Specification	Note
1	Received Signal Amplitude	≥350mV	1Vp-p / 20 Pulses Interval 20ms at 1MHz
2	Maximum Input Voltage	5Vp-p	At 1MHz
3	Maximum Allowable Working Pressure	1.6Mpa	
4	Installation Length	110mm	Vernier Caliper
5	Connecting Thread	G3/4	Thread Gauge
6	Operating Temperature	0.1~+50°C	
7	Storage Temperature	-25~+55°C	
8	Pressure Loss	≤40Kpa	Q=2.5m ³ /h, T<30°C
9	Installation Position	Inlet	
10	Installation Mode	Threaded connection	

3. Appearance and dimensions: Unit:mm



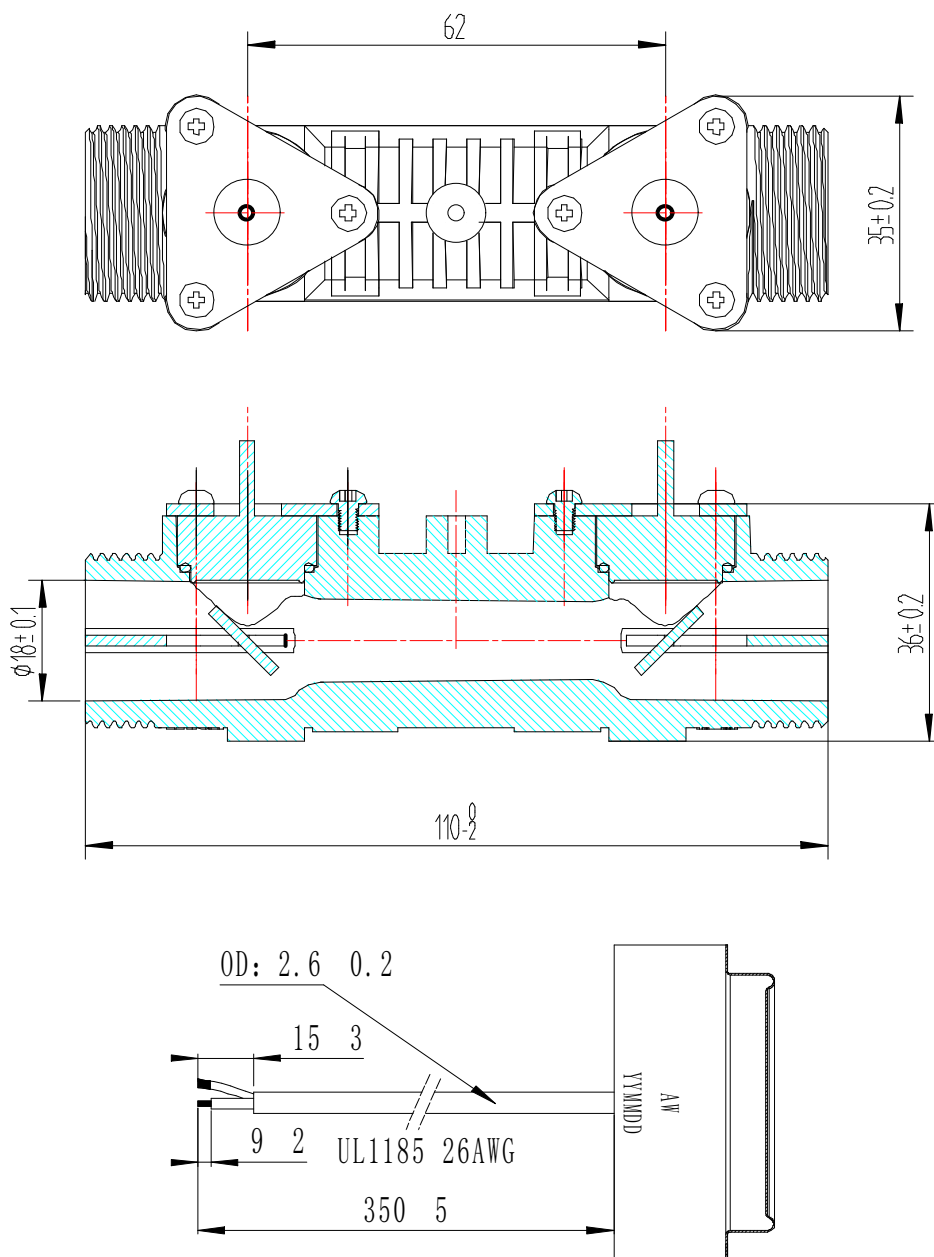

■ Package:

Pcs/box	External packing box dimension (cm)	Packing case dimension (cm)	Gross weight(kg)	Net weight(kg)
100	47.8*28*22	22.5*12.5*3.8	12.1	10.7

■ Note

1. The measurement error with temperature change is recorded when the product is



connected to Audiowell's circuit board. The measurement error is not guaranteed when the product is used with other circuit boards.

2. The maximum permissible hydrostatic pressure is 3.2MPa.
3. This product should only be used for water and homogeneous liquid measurement. Do not use the product for air flow measurement.
4. Precautions should be taken to prevent interference in the design of drive circuit.
5. To avoid accidents caused by product failure, the design of secondary products should include failure protection.
6. To prevent fault, failure and performance degradation of the sensors, avoid use this product in the following or similar conditions:
 - a. Intense shock or vibration;
 - b. In the environments that contain dissolved organic matter;
 - c. The input voltage exceeds the rated maximum input voltage.

