



SHENZHEN ZHUO XIN TECHNOLOGY CO., LTD

room12208 , A #yikang business building , No , 33 huarong road , dalang longhua area , shenzhen , China

(Tel): +86-755-23737634

<http://www.zhuoxkej.com>

Li-ion Battery Specification

MODEL: 703759P-3.7V-2000mAh
LM72000

Prepared By/Date	Checked By/Date	Approved By/Date
2017/11/08	王艳林	黄新屋

Customer Approval	Signature/Date
	Company Name
	Company Stamp



SHENZHEN ZHUO XIN TECHNOLOGY CO., LTD

room12208 , A #yikang business building , No , 33 huarong road , dalang longhua area , shenzhen , China

(Tel): +86-755-23737634

<http://www.zhuoxkej.com>

Amendment Records

Edition	Description	Prepared by	Approved by	Date
A	First Edition			

 茁欣科技	SHENZHEN ZHUO XIN TECHNOLOGY CO., LTD
	room12208 , A #yikang business building , No , 33 huarong road , dalang longhua area , shenzhen , China (Tel): +86-755-23737634 http://www.zhuoxkej.com

1 Scope

This specification is applied to the reference battery in this Specification and manufactured by ZHUOXIN Technology Co., Ltd.

2 Product Specification

Table 1

No.	Item	General Parameter		Remark
		Typical		
1	Rated Capacity	2000mAh		Standard discharge (0.2C _{5A}) after Standard charge
		1900mAh		
2	Nominal Voltage	3.7V		Mean Operation Voltage
3	Voltage at end of Discharge	2.75V		Discharge Cut-off Voltage
4	Battery limit voltage	4.2V		
5	Internal Impedance	≤150m Ω		Internal resistance measured at AC 1KHz after 50% charge The measure must uses the new batteries that within one week after shipment and cycles less than 5 times
6	Standard charge	Constant Current 0.5C _{5A} Constant Voltage 4.2V 0.01 C _{5A} cut-off		Charge time : Approx 4.0h
7	Standard discharge	Constant current 0.2 C _{5A} end voltage 2.75V		
8	Fast charge	Constant Current 1C _{5A} Constant Voltage 4.2V 0.01 C _{5A} cut-off A)		Charge time : Approx 2.5h



SHENZHEN ZHUO XIN TECHNOLOGY CO., LTD

room12208 , A #yikang business building , No , 33 huarong road , dalang longhua area , shenzhen , China

(Tel): +86-755-23737634

<http://www.zhuoxkej.com>

Continuous the table 1

No.	Item	General Parameter	Remark
9	Maximum Continuous Charge Current	1C ₅ A	
10	Maximum Continuous Discharge Current	1C ₅ A	
11	Operation Temperature Range	Charge: 0~45°C	60±25%R.H. Bare Cell
		Discharge: -20~60°C	
12	Storage Temperature Range	Less than 1 months 20~60°C	60±15%R.H. at the shipment state
		less than 6 months: -20~30°C	
		Charge quantity 50%~60%	



SHENZHEN ZHUO XIN TECHNOLOGY CO., LTD

room12208 , A #yikang business building , No , 33 huarong road , dalang longhua area , shenzhen , China

(Tel): +86-755-23737634

<http://www.zhuoxkej.com>

3 Performance And Test Conditions

3.1 Standard Test Conditions

Test should be conducted with new batteries within one week after shipment from our factory and the cells shall not be cycled more than five times before the test. Unless otherwise specified, test and measurement shall be done under temperature of $20 \pm 5^\circ\text{C}$ and relative humidity of 45~75%. If it is judged that the test results are not affected by such conditions, the tests may be conducted at temperature $15 \sim 30^\circ\text{C}$ and humidity 25~75%RH.

3.2 Measuring Instrument or Apparatus

3.2.1 Dimension Measuring Instrument

The dimension measurement shall be implemented by instruments with equal or more precision scale of 0.01mm.

3.2.2 Voltmeter

Standard class specified in the national standard or more sensitive class having inner impedance more than $10\text{k}\Omega/\text{V}$

3.2.3 Ammeter

Standard class specified in the national standard or more sensitive class. Total external resistance including ammeter and wire is less than 0.01Ω .

3.2.4 Impedance Meter

Impedance shall be measured by a sinusoidal alternating current method(1kHz LCR meter).

3.3 Standard Charge\Discharge

$0.5C_5A = 1000\text{mA}$

Charging shall consist of charging at a $0.5C_5A$ constant current rate until the cell reaches 4.2V. The cell shall then be charged at constant voltage of 4.2V volts while tapering the charge current. Charging shall be terminated when the charging current has tapered to $0.01 C_5A$. Charge time : Approx 4.5h, The cell shall demonstrate no permanent degradation when charged between 0°C and 45°C .

3.3.2 Standard Discharge

$0.2C_5A = 400\text{mA}$

Cells shall be discharged at a constant current of $0.2C_5A$ to 2.75volts @ $20^\circ \pm 5\text{C}$

3.3.3 If no otherwise specified, the rest time between Chare and Discharge amount to 30min.

	SHENZHEN ZHUO XIN TECHNOLOGY CO., LTD
	room12208 , A #yikang business building , No , 33 huarong road , dalang longhua area , shenzhen , China (Tel): +86-755-23737634 http://www.zhuoxkej.com

3.4 Appearance

There shall be no such defect as flaw, crack, rust, leakage, which may adversely affect commercial value of battery.

3.5 Initial Performance Test

Table 2

Item	Test Method and Condition	Requirements
(1) Cell Voltage	As of shipment	$\geq 3.7V$
(2) Open-Circuit Voltage	The open-circuit voltage shall be measured within 24 hours after standard charge.	$\geq 4.08V$
(3) Internal impedance	Internal resistance measured at AC 1KHz after 50% charge.	$\leq 150m\Omega$
(4) Minimal Rated Capacity	The capacity on $0.2C_5A$ discharge till the voltage tapered to 2.75V shall be measured after rested for 30min then finish standard charge.	Discharge Capacity $\geq 2000mAh$

3.6 Temperature Dependence of discharge capacity

Cells shall be charged per 3.3.1 and discharged @ $0.2 C_5A$ to 5.5 volts. Except to be discharged at temperatures per Table 3. Cells shall be stored for 3 hours at the test temperature prior to discharging and then shall be discharged at the test temperature. The capacity of a cell at each temperature shall be compared to the capacity achieved at 23 °C and the percentage shall be calculated. Each cell shall meet or exceed the requirements of Table 3.

Table 3

Discharge Temperature	-20°C	-10°C	0°C	23°C	60°C
Discharge Capacity ($0.2 C_5A$)	50%	60%	80%	100%	95%



SHENZHEN ZHUO XIN TECHNOLOGY CO., LTD

room12208 , A #yikang business building , No , 33 huarong road , dalang longhua area , shenzhen , China

(Tel): +86-755-23737634

<http://www.zhuoxkej.com>

3.7 Cycle Life and Leakage-Proof

Table 4

No.	Item	Criteria	Test Conditions
1	Cycle Life (1C ₅ A)	Higher than 70% of the Initial Capacities of the Cells	Carry out 500cycle Charging/Discharging in the below condition. ◆Charge:Standard Charge, per 3.3.1 ◆Discharge: Standard discharge, per 3.3.2 ◆Rest Time between charge/discharge:30min. ◆Temperature:20±5℃

4. Mechanical characteristics and Safety Test

Table 5

(Mechanical characteristics)

No.	Items	Test Method and Condition	Criteria
1	Vibration Test	After standard charging, fixed the cell to vibration table and subjected to vibration cycling that the frequency is to be varied at the rate of 1Hz per minute between 10Hz an 55Hz, the excursion of the vibration is 1.6mm. The cell shall be vibrated for 30 minutes per axis of XYZ axes.	No leakage No fire
2	Drop Test	The cell is to be dropped from a height of 1 meter twice onto concrete ground.	No explosion, No fire, no leakage.
3	Collisions	After the vibration test, according to X.Y.Z each battery average three vertical pulse peak acceleration, the setting for the 100m/s ² , every minute, 40 ~ 80 collision frequency, pulse duration 16ms collision frequency ± 10 thousand.	No explosion, No fire, no leakage.

	SHENZHEN ZHUO XIN TECHNOLOGY CO., LTD
	room12208 , A #yikang business building , No , 33 huarong road , dalang longhua area , shenzhen , China (Tel): +86-755-23737634 http://www.zhuoxkej.com

Table 6

No.	Item	Battery Condition	Test Method	Requirements
4	Crush	Fresh, Fully charged	Crush between two flat plates. Applied force is about 13kN(1.72Mpa) for 30min.	No explosion, No fire
5	Short Circuit	Remove outer protective circuit	This test will be placed the battery electric dipole in the fume hood, short-circuit the anode (total resistance is not more than 50m lines Ω), monitor temperature changes, when the battery is low temperature dropped to about 10 degrees than peak, the end of experiment.	No explosion, No fire The Temperature of the surface of the Cells are lower than 150°C
6	Impact	Fresh, Fully charged	A 56mm diameter bar is inlaid into the bottom of a 10kg weight. And the weight is to be dropped from a height of 1m onto a sample battery and then the bar will be across the center of the sample.	No explosion, No fire
7	Thermal shock	Fresh, Fully charged	Batteries in hot box Temperature in $5^{\circ}\text{C} \pm 2^{\circ}\text{C}/\text{min}$, rising to $130^{\circ}\text{C} \pm 2^{\circ}\text{C}$ keep 30min.	No explosion, No fire
8	Forced Discharge	Fresh, Fully charged	Discharge at a current of 1 C ₅ A for 2.5h.	No explosion, No fire



SHENZHEN ZHUO XIN TECHNOLOGY CO., LTD

room12208 , A #yikang business building , No , 33 huarong road , dalang longhua area , shenzhen , China

(Tel): +86-755-23737634

<http://www.zhuoxkej.com>

Table 6

No.	Item	Battery Condition	Test Method	Requirements
9	High temperature performance	Fresh, Fully charged	After charging Will a battery into $55 \pm 2^{\circ}\text{C}$ In the case of high temperature 2h Batteries in $55 \pm 2^{\circ}\text{C}$ $1\text{C}_5\text{A}$ discharge current to the termination voltage, discharge time should not below 51min., Battery will in environmental temperature $20^{\circ}\text{C} \pm 5^{\circ}\text{C}$ place 2h	No explosion, No fire
10	Low temperature performance	Fresh, Fully charged	After charging, will be a battery into -20 ± 2 degrees Celsius in the box, then 16h constant 24h $\sim 0.2\text{C}_5\text{A}$ with discharge current to the termination voltage, discharge time should not below 3h. After the experiment, the battery will in environmental temperature of $20 \pm 5^{\circ}\text{C}$ condition 2h aside	No deformation and burst
11	Charged	Fresh, Fully charged	A full battery, at ambient temperature $20 \pm 5^{\circ}\text{C}$ under the conditions of the battery will be open to 28d aside, $0.2\text{C}_5\text{A}$ to terminate discharge current voltage,	the discharge time not below 4.25 h.
12	Constant damp performance	Fresh, Fully charged	Standard after the battery, Will a battery into $40^{\circ}\text{C} \pm 2^{\circ}\text{C}$, Relative humidity $90\% \sim 95\%$ At constant temperature and humidity box after 48h Battery will in environmental temperature $20^{\circ}\text{C} \pm 5^{\circ}\text{C}$ Aside 2h, $0.2\text{C}_5\text{A}$ to terminate discharge current voltage,	No obvious deformation, hands rust, smoke, explosion, discharge time not less than 36 min



SHENZHEN ZHUO XIN TECHNOLOGY CO., LTD

room12208 , A #yikang business building , No , 33 huarong road , dalang longhua area , shenzhen , China

(Tel): +86-755-23737634

<http://www.zhuoxkej.com>

5. Handling of Cells

5.1 Consideration of strength of film package

1) Soft Aluminium foil

Easily damaged by sharp edge parts such as pins and needles, Ni-tabs, comparing with metal-can-cased LIB.

2). Sealed edge may be damaged by heat above 100°C, bend or fold sealed edge.

5.2 Prohibition short circuit

Never make short circuit cell. It generates very high current which causes heating of the cells and may cause electrolyte leakage, gassing or explosion that are very dangerous.

The LIP tabs may be easily short-circuited by putting them on conductive surface.

Such outer short circuit may lead to heat generation and damage of the cell.

An appropriate circuitry with PCM shall be employed to protect accidental short circuit of the battery pack.

5.3. Mechanical shock

LIP cells have less mechanical endurance than metal-can-cased LIB.

Falling, hitting, bending, etc. may cause degradation of LIP characteristics.

5.4 Handling of tabs

The battery tabs are not so stubborn especially for aluminum tab.

Don't bend tab.

Do not bend tabs unnecessarily.

6. Notice for Designing Battery Pack

6.1 Pack toughness

Battery pack should have sufficient strength and the LIP cell inside should be protected from mechanical shocks.

6.2 Cell fixing

The LIP cell should be fixed to the battery pack by its CXPOWER surface area.

No cell movement in the battery pack should be allowed.

6.3 Inside design

No sharp edge components should be inside the pack containing the LIP cell.

6.4 Tab connection

Ultrasonic welding or spot welding is recommended for LIP tab connection method.

Battery pack should be designed that shear force are not applied to the LIP tabs.

If apply manual solder method to connect tab with PCM, below notice is very important to ensure battery performance:



SHENZHEN ZHUO XIN TECHNOLOGY CO., LTD

room12208 , A #yikang business building , No , 33 huarong road , dalang longhua area , shenzhen , China

(Tel): +86-755-23737634 <http://www.zhuoxkej.com>

- The solder iron should be temperature controlled and ESD safe;
- Soldering temperature should not exceed 350°C;
- Soldering time should not be longer than 3s;
- Soldering times should not exceed 5 times, Keep battery tab cold down before next time soldering;
- Directly heat cell body is strictly prohibited, Battery may be damaged by heat above approx. 100°C

6.5 For mishaps

Battery pack should be designed not to generate heat even when leakage occurs due to mishaps.

- 1) Isolate PCM (Protection Circuit Module) from leaked electrolyte as perfectly as possible.
- 2) Avoid narrow spacing between bare circuit patterns with different voltage.
(Including around connector)
- 3) LIP battery should not have liquid from electrolyte, but in case If leaked electrolyte touch bare circuit patterns, higher potential terminal material may dissolve and precipitate at the lower potential terminal, and may cause short circuit. The design of the PCB must have this covered.

7. Notice for Assembling Battery Pack

Shocks, high temperature, or contacts of sharp edge components should not be allowed in battery pack assembling process.

8. Others

8.1. Cell connection

- 1) Direct soldering of wire leads or devices to the cell is strictly prohibited.
- 2) Lead tabs with pre-soldered wiring shall be spot welded to the cells.
Direct soldering may cause damage of components, such as separator and insulator, by heat generation.

8.2. Prevention of short circuit within a battery pack

Enough insulation layers between wiring and the cells shall be used to maintain extra safety protection.

The battery pack shall be structured with no short circuit within the battery pack, which may cause generation of smoke or firing.

8.3. Prohibition of disassembly

- 1) Never disassemble the cells
The disassembling may generate internal short circuit in the cell, which may cause gassing, firing, explosion, or other problems.
- 2) Electrolyte is harmful
LIP battery should not have liquid from electrolyte flowing, but in case the electrolyte come into contact with the skin, or eyes, physicians shall flush the electrolyte immediately with fresh water and medical advice is to be sought.



SHENZHEN ZHUO XIN TECHNOLOGY CO., LTD

room12208 , A #yikang business building , No , 33 huarong road , dalang longhua area , shenzhen , China

(Tel): +86-755-23737634

<http://www.zhuoxkej.com>

8.4 Prohibition of dumping of cells into fire

Never incinerate nor dispose the cells in fire. These may cause explosion of the cells, which is very dangerous and is prohibited.

8.5 Prohibition of cells immersion into liquid such as water

The cells shall never be soaked with liquids such as water, seawater, drinks such as soft drinks, juices, coffee or others.

8.6 Battery cells replacement

The battery replacement shall be done only by either cells supplier or device supplier and never be done by the user.

8.7 Prohibition of use of damaged cells

The cells might be damaged during shipping by shock. If any abnormal features of the cells are found such as damages in a plastic envelop of the cell, deformation of the cell package, smelling of an electrolyte, an electrolyte leakage and others, the cells shall never be used any more.

The Cells with a smell of the electrolyte or a leakage shall be placed away from fire to avoid firing or explosion.

9. Period of Warranty

The delivery period from battery date for 12 months If the battery is proved in manufacturing process

defect formation rather than the user abuse and error caused by use of this company is responsible for replacement battery.

10. Storing the Batteries

The batteries should be stored at room temperature, charged to about 30% to 50% of capacity. We recommend that batteries be charged about once per half 3 months to prevent over discharge.

11. Other The Chemical Reaction

Because batteries utilize a chemical reaction, battery performance will deteriorate over time even if stored for a long period of time without being used. In addition, if the various usage conditions such as charge, discharge, ambient temperature, etc. are not maintained within the specified ranges the life expectancy of the battery may be shortened or the device in which the battery is used may be damaged by electrolyte leakage. If the batteries cannot maintain a charge for long periods of time, even when they are charged correctly, this may indicate it is time to change the battery.

12. Note:

Any other items which are not covered in this specification shall be agreed by both parties.



SHENZHEN ZHUO XIN TECHNOLOGY CO., LTD

room12208 , A #yikang business building , No , 33 huarong road , dalang longhua area , shenzhen , China

(Tel): +86-755-23737634

<http://www.zhuoxkej.com>

13. Protection circuit

13.1 PCB Standard

		Page	1
No	Item	Condition	Specification
1	input Voltage	/input Voltage B+ to B-	-0.3~+10V
2	Overcharge	Detection voltage	4.300±0.050V
3		Release voltage	4.100±0.050V
4		Detection delay time	≤200mS
5	Over discharge	Detection voltage	2.400±0.100V
6		Release voltage	3.000±0.100V
7		Detection delay time	≤100mS
8	Over discharge current	Over current	4.00~9.00 A
9		delay time	≤20mS
10	Short circuit protection	Short detection delay time	≤50uS
11		Release Conditions	Cut off load
12	Normal current consumption	Normal current consumption of PCM	Max 6.00uA
14	charger	allowed 0V change	NO
15	Suggest working conditions	max continuous discharge current	2.00A
16		suggest working temperature	-20~60℃
17	IR resistance	IR of PCM	≤65.00 mΩ



SHENZHEN ZHUO XIN TECHNOLOGY CO., LTD

room12208 , A #yikang business building , No , 33 huarong road , dalang longhua area , shenzhen , China

(Tel): +86-755-23737634

<http://www.zhuoxkej.com>

13.2 Schematic diagram

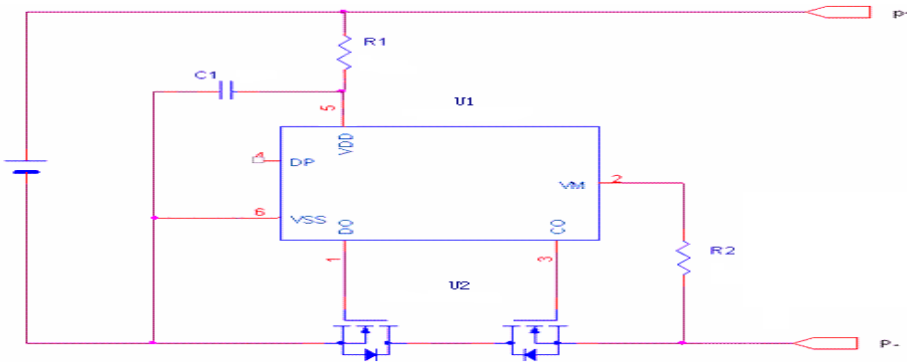

13.3 PCB Top Overlay (

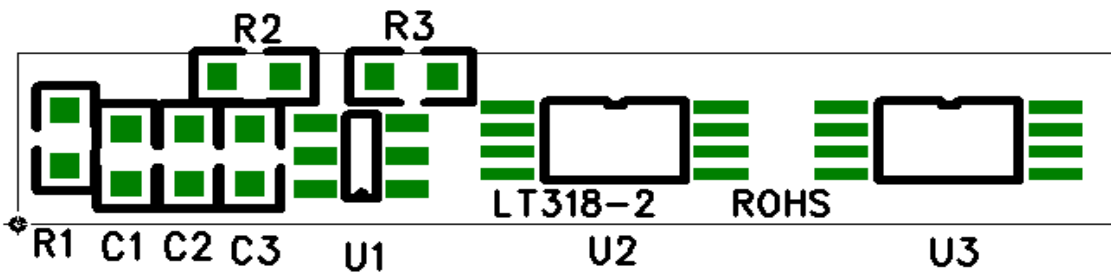

13.4 PCB-BOM

Location	Description	/part No. Specification	Size	Qty	Vendor	ROHS	Remark
U1	ICProtection IC	DW01+G	SOT-23-6	1	FORTUNE	ROHS	
U2,U3	MOSFET SMD MOSFET	SIS8205A	TSSOP-8	2		ROHS	
R1	SMD Resistance	100Ω, ± 5%, 1/10W	0603	1	YAGEO	ROHS	
R2	SMD Resistance	1KΩ, ± 5%, 1/10W	0603	1	YAGEO	ROHS	
C1	SMD Capacitance	0.1uF, -20% +80%, 50V	0603	1	YAGEO	ROHS	
B+/B-	Nickel sheet	NS4503500 30TA	4.5*3.5*0.3 mm	2	/	ROHS	



SHENZHEN ZHUO XIN TECHNOLOGY CO., LTD

room12208 , A #yikang business building , No , 33 huarong road , dalang longhua area , shenzhen , China

(Tel): +86-755-23737634 <http://www.zhuoxkej.com>

15. Initial Dimension:



The BOM of cell group

NO	Part name	Quantity	Unit	Remark
1	Cell	1	ea	703759P
2	PCBA	1	ea	1
3	Wire	1	Ea	JST-PH-2Pin
4	Solder	0.2	g	Lead Free

Units	mm	La	150	Lb		Lc	
L1=L2=L3		T	6.5	W	39.5	H	63.6
Drawer	张勇	Checked	王艳林	Approved	黄新屋	Date	2017-11-08

茁欣科技

ZX703759P×1P DRAWING

Drawing ID	LM7200
------------	--------